

4

3

2

1

ITEM NO.	PART NUMBER	DESCRIPTION	DESCRIPTION 2	QTY.
1	POLE	POLE, DIRECT BURIAL	-	1
2	TEN-0001	2-3/8" O.D. TENON	3-1/2" HEIGHT	1
3	COV-0012	HANDHOLE COVER, 2-1/2" X 5"	ROUND TAPERED	1
4	RN0250-0003	RIVET NUT, 1/4-20	.280 - .500 GRIP RANGE	2
5	PS0250-0008	PHILLIPS SCREW 1/4"-20 X 1"	ZINC	2

ECO		REV.	DESCRIPTION	DATE	INITIALS

FEATURE ORIENTATIONS

	0°	90°	180°	270°
CABLE ENTRY	X			
HAND HOLE	X			

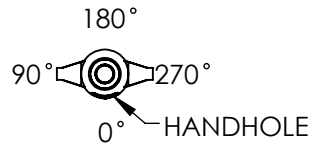

NOTE: ALL HOLES DRILLED ONLY THROUGH THE FACES SPECIFIED BY 'X'

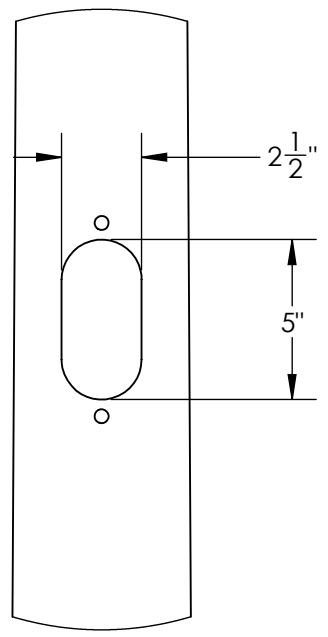
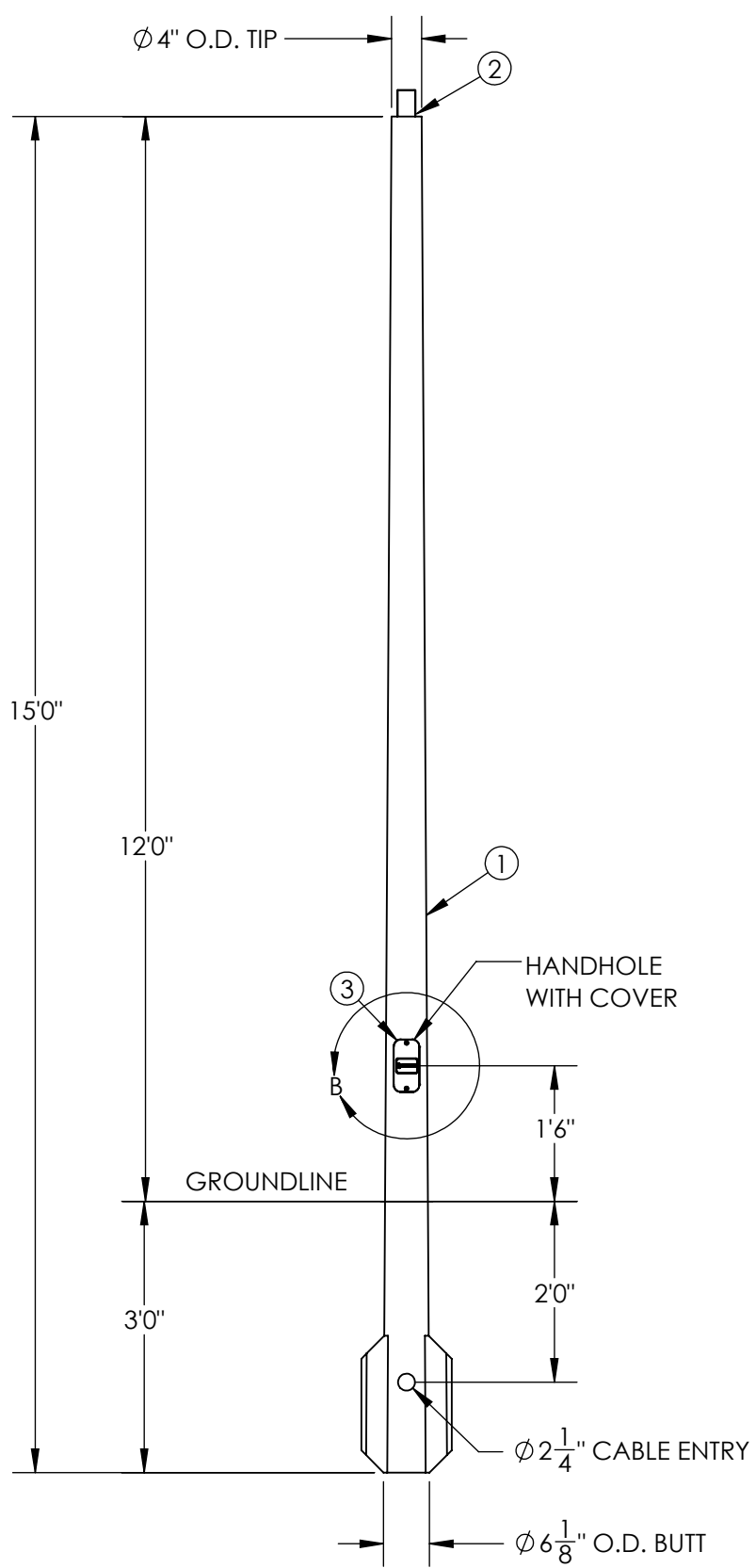

DETAIL B  
HANDHOLE CUTOUT  
COVER REMOVED FOR CLARITY  
SCALE 1 : 6

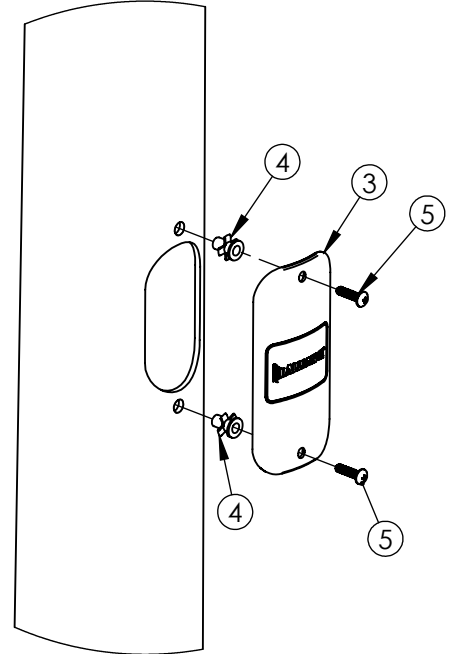

DETAIL A  
COVER ASSEMBLY  
SCALE 1 : 6

MAXIMUM EPA PER WINDZONE										
MPH	90	100	110	120	130	140	150	160	170	180
EPA	11.9	9.2	7.2	5.7	4.6	4.3	3.6	3.1	2.7	2.3

- NOTES:
- DIRECT BURIAL CLASS 1 POLE PER ASTM 4923. POLE TOP DEFLECTION SHALL NOT EXCEED 15% OF THE ABOVE GROUND HEIGHT AT MAXIMUM WIND LOADING AND MAXIMUM FIXTURE WEIGHT.
  - DESIGN CRITERIA PER AASHTO LTS-6-2013 WITH A MINIMUM SAFETY FACTOR OF 1.5 PER ANSI C136.20-2012.
  - WIND SPEEDS DEFINED AS 3 SECOND GUST PER ASCE 7-16 WITH VELOCITY CONVERSIONS PER 2018 IBC 1609.3.1.
  - EMBEDMENT BASED ON MINIMUM DEPTH RECOMMENDED BY ANSI C136.20-2012 SECTION 5.3 AND ASSUMING CLASS 1 SOIL OR BETTER WHEN LOADED AT MAXIMUM EPA.

N = NATURAL FINISH  
S = SMOOTH FINISH

D3TI15F00↑2↓GXHHM

G = GRAY  
A = BLACK  
F = BRONZE  
W = WHITE  
N = GREEN

---UNLESS OTHERWISE SPECIFIED---  
DIMENSION UNITS ARE IN FEET AND INCHES  
DIMENSIONS SHOWN ARE NOMINAL



PROPRIETARY AND CONFIDENTIAL  
THE INFORMATION CONTAINED IN THIS DRAWING IS THE SOLE PROPERTY OF GEOTEK. ANY REPRODUCTION IN PART OR AS A WHOLE WITHOUT THE WRITTEN PERMISSION OF GEOTEK IS PROHIBITED.

CUSTOMER SIGNATURE: \_\_\_\_\_ DATE: \_\_\_\_\_

STATE:	RELEASED	2024-01-16
DRAWN:	AJH	2024-01-11
CHECKED:	IAB	2024-01-12
APPROVED:	AJH	2024-01-16
REPLACES:	-	

THIRD ANGLE PROJECTION

---REFERENCES---  
alliancecompositesinc.com/warranty  
geotek.com/termsandconditions

DESCRIPTION:  
**POLE ASSEMBLY, DIRECT BURIAL INTERMEDIATE DUTY, 15FT**

1421 SECOND AVE NW  
STEWARTVILLE, MN 55976  
(800) 533-1680  
www.geotek.com

SIZE: DWG. NO. **B D3TI15F00X2XGXHHM**

SCALE: 1:24

POLE COLOR: REV: 0.0

SHEET 1 OF 1

4

3

2

1