

4

3

2

1

ITEM NO.	PART NUMBER	DESCRIPTION	DESCRIPTION 2	QTY.
1	POLE	POLE, DIRECT BURIAL	-	1
2	TEN-0001	2-3/8" O.D. TENON	3-1/2" HEIGHT	1
3	COV-0012	HANDHOLE COVER, 2-1/2" X 5"	ROUND TAPERED	1
4	RN0250-0003	RIVET NUT, 1/4-20	.280 - .500 GRIP RANGE	2
5	PS0250-0008	PHILLIPS SCREW 1/4"-20 X 1"	ZINC	2

ECO		REV.	DESCRIPTION	DATE	INITIALS

FEATURE ORIENTATIONS

	0°	90°	180°	270°
CABLE ENTRY	X			
HAND HOLE	X			

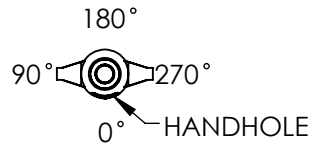

NOTE: ALL HOLES DRILLED ONLY THROUGH THE FACES SPECIFIED BY 'X'

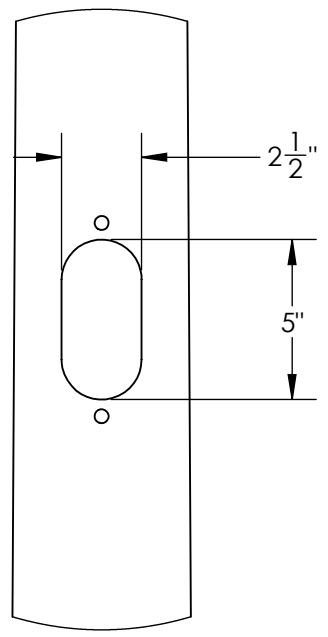
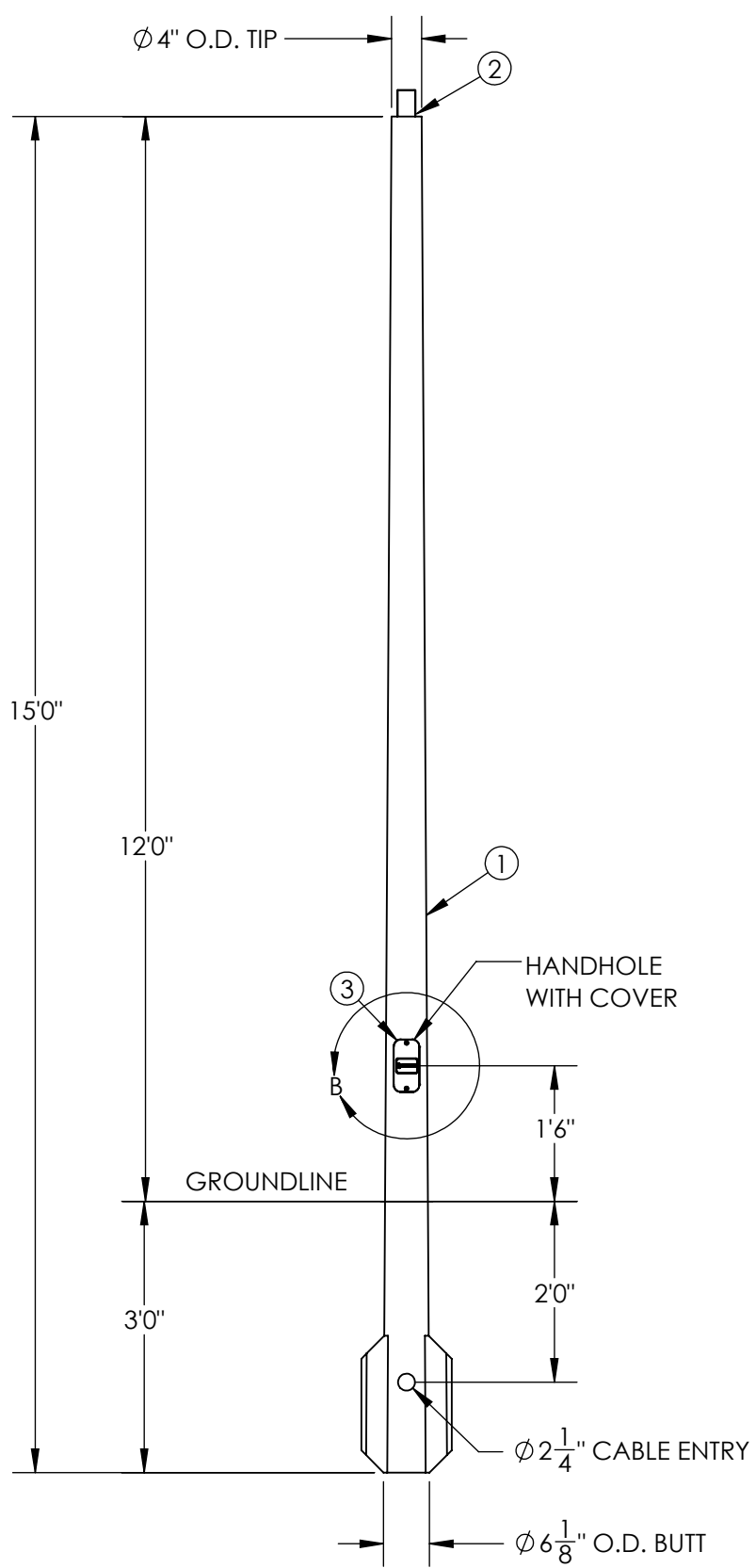

DETAIL B
HANDHOLE CUTOUT
COVER REMOVED FOR CLARITY
SCALE 1 : 6

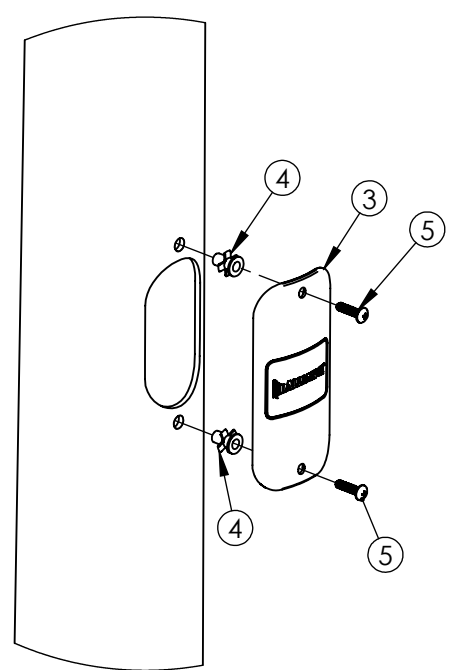

DETAIL A
COVER ASSEMBLY
SCALE 1 : 6

MAXIMUM EPA PER WINDZONE										
MPH	90	100	110	120	130	140	150	160	170	180
EPA	15.2	11.9	9.4	7.5	6.2	5.9	5.0	4.3	3.7	3.2

- NOTES:
- DIRECT BURIAL CLASS 1 POLE PER ASTM 4923. POLE TOP DEFLECTION SHALL NOT EXCEED 15% OF THE ABOVE GROUND HEIGHT AT MAXIMUM WIND LOADING AND MAXIMUM FIXTURE WEIGHT.
 - DESIGN CRITERIA PER AASHTO LTS-6-2013 WITH A MINIMUM SAFETY FACTOR OF 1.5 PER ANSI C136.20-2012.
 - WIND SPEEDS DEFINED AS 3 SECOND GUST PER ASCE 7-16 WITH VELOCITY CONVERSIONS PER 2018 IBC 1609.3.1.
 - EMBEDMENT BASED ON MINIMUM DEPTH RECOMMENDED BY ANSI C136.20-2012 SECTION 5.3 AND ASSUMING CLASS 1 SOIL OR BETTER WHEN LOADED AT MAXIMUM EPA.

N = NATURAL FINISH
S = SMOOTH FINISH

D3TH15F00↑2↓GXHHM

G = GRAY
A = BLACK
F = BRONZE
W = WHITE
N = GREEN

---UNLESS OTHERWISE SPECIFIED---
DIMENSION UNITS ARE IN FEET AND INCHES
DIMENSIONS SHOWN ARE NOMINAL



STATE: RELEASED 2024-01-16
DRAWN: AJH 2024-01-11
CHECKED: NDH 2024-01-12
APPROVED: AJH 2024-01-16
REPLACES: -

PROPRIETARY AND CONFIDENTIAL
THE INFORMATION CONTAINED IN THIS DRAWING IS THE SOLE PROPERTY OF GEOTEK. ANY REPRODUCTION IN PART OR AS A WHOLE WITHOUT THE WRITTEN PERMISSION OF GEOTEK IS PROHIBITED.

CUSTOMER SIGNATURE: _____ DATE: _____

THIRD ANGLE PROJECTION

-REFERENCES-
alliancecompositesinc.com/warranty
geotek.com/termsandconditions

DESCRIPTION:
**POLE ASSEMBLY, DIRECT BURIAL
HEAVY DUTY, 15FT**

1421 SECOND AVE NW
STEWARTVILLE, MN 55976
(800) 533-1680
www.geotek.com

SIZE: DWG. NO. **B D3TH15F00X2XGXHHM**

SCALE: 1:24

POLE COLOR: REV: 0.0

SHEET 1 OF 1

4

3

2

1