

4

3

2

1

ITEM NO.	DESCRIPTION	QTY.
1	BEAM, PULTRUDED STOCK	1
2	RIVET NUT, 1/4-20	2
3	HANDHOLE COVER	1
4	PHILLIPS SCREW, 1/4"-20x3/4"	2
5	TOP CAP	1
6	HEX SCREW, #8-18 x 1 in	2

REVISIONS				
REV.	DESCRIPTION	DATE	INITIALS	ECO
0.1	UPDATE NOTES	7/11/2023	AJH	6243

FEATURE ORIENTATIONS				
	0°	90°	180°	270°
HAND HOLE	X			
CABLE ENTRY	X			

NOTE: ALL HOLES DRILLED ONLY THROUGH THE FACES SPECIFIED BY 'X'

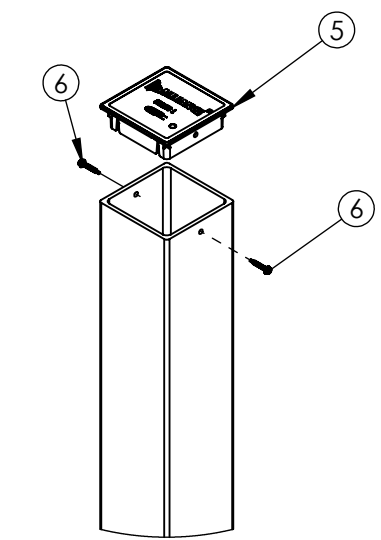
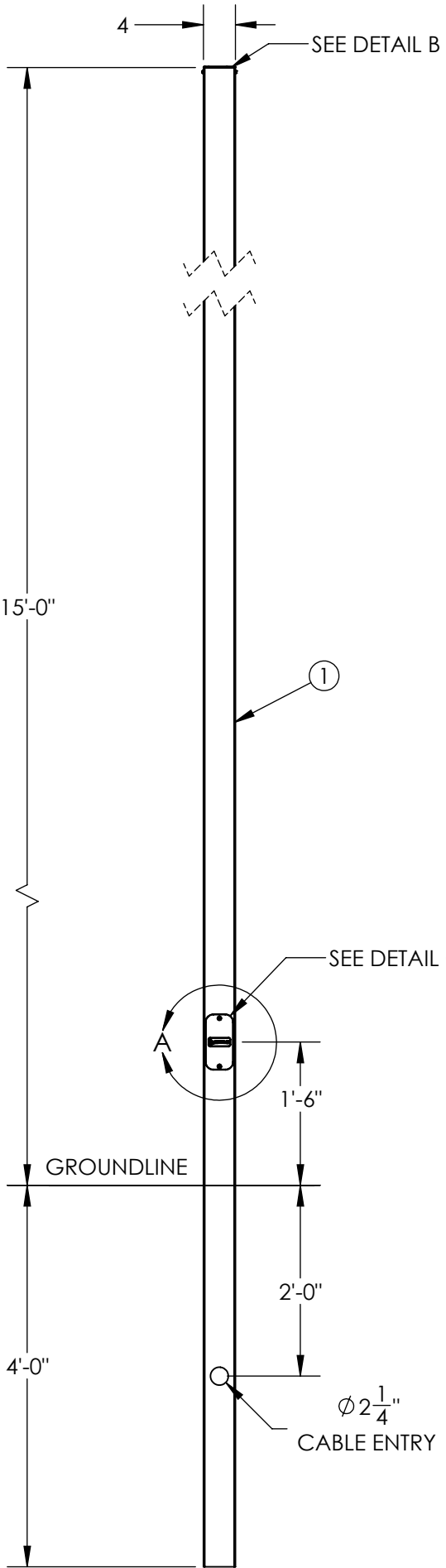
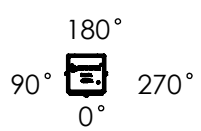

DETAIL B
TOP CAP ASSEMBLY
SCALE 1 : 8

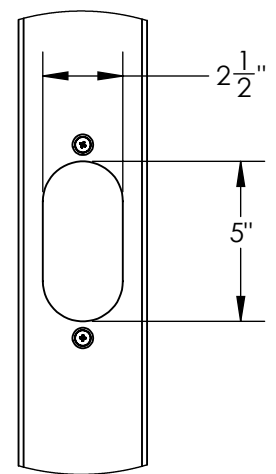

DETAIL A
HANDHOLE CUTOUT
COVER REMOVED FOR CLARITY
SCALE 1 : 6

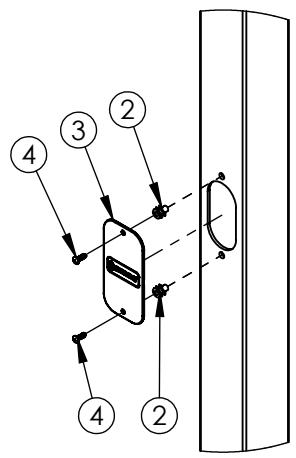

DETAIL C
COVER ASSEMBLY
SCALE 1 : 12

BUILD	STANDARD
FINISH	SMOOTH

MAXIMUM EPA PER WINDZONE										
MPH	90	100	110	120	130	140	150	160	170	180
EPA	12.9	9.7	7.2	5.4	4.1	3.8	2.8	1.9	1.2	0.6

- NOTES:
1. DIRECT BURIAL CLASS 1 POLE PER ASTM 4923. POLE TOP DEFLECTION SHALL NOT EXCEED 15% OF THE ABOVE GROUND HEIGHT AT MAXIMUM WIND LOADING AND MAXIMUM FIXTURE WEIGHT.
 2. DESIGN CRITERIA PER AASHTO LTS-6-2013 WITH A MINIMUM SAFETY FACTOR OF 1.5 PER ANSI C136.20-2012.
 3. WIND SPEEDS DEFINED AS 3 SECOND GUST PER ASCE 7-16 WITH VELOCITY CONVERSIONS PER 2018 IBC 1609.3.1.
 4. EMBEDMENT BASED ON MINIMUM DEPTH RECOMMENDED BY ANSI C136.20-2012 SECTION 5.3 AND ASSUMING CLASS 1 SOIL OR BETTER WHEN LOADED AT MAXIMUM EPA.

D4SS19F00S1 ↓ GXHH

- G = GRAY
- A = BLACK
- F = BRONZE
- W = WHITE
- N = GREEN

---UNLESS OTHERWISE SPECIFIED---
DIMENSION UNITS ARE IN FEET AND INCHES
DIMENSIONS SHOWN ARE NOMINAL

STATE:	RELEASED	2023-07-11
DRAWN:	CJM	2023-06-20
CHECKED:	DMF	2023-07-11
APPROVED:	AJH	2023-07-11
REPLACES:		



PROPRIETARY AND CONFIDENTIAL
THE INFORMATION CONTAINED IN THIS DRAWING IS THE SOLE PROPERTY OF GEOTEK. ANY REPRODUCTION IN PART OR AS A WHOLE WITHOUT THE WRITTEN PERMISSION OF GEOTEK IS PROHIBITED.

THIRD ANGLE PROJECTION

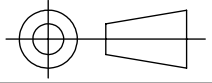

CUSTOMER SIGNATURE:

DATE:

DESCRIPTION:
**POLE SYSTEM, DIRECT BURIAL
STANDARD DUTY, 19 FT**

1421 SECOND AVE NW
STEWARTVILLE, MN 55976
(800) 533-1680
www.geotek.com

SIZE: DWG. NO.

B D4SS19F00S1XGXHH

POLE COLOR:

REV:

0.1

SCALE: 1:18

SHEET 1 OF 1