

4

3

2

1

ITEM NO.	DESCRIPTION	QTY.
1	BEAM, PULTRUDED STOCK	1
2	ANCHOR BASE, 4" SQUARE	1
3	HEX BOLT	1
4	FLANGE NUT, SERRATED	1
5	TOP CAP	1
6	HEX SCREW, SELF-TAPPING	2
7	RIVET NUT, 1/4-20	2
8	HANDHOLE COVER	1
9	PHILLIPS SCREW, 1/4"-20x3/4"	2

REVISIONS				
REV.	DESCRIPTION	DATE	INITIALS	ECO
0.1	UPDATE NOTES	7/11/2023	AJH	6243

FEATURE ORIENTATIONS				
	0°	90°	180°	270°
HAND HOLE	X			

NOTE: ALL HOLES DRILLED ONLY THROUGH THE FACES SPECIFIED BY 'X'

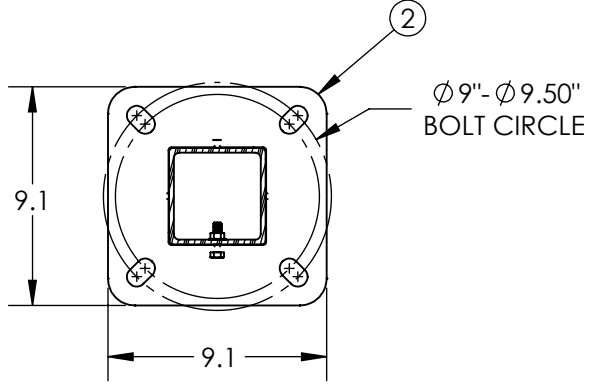

SECTION B-B
SCALE 1 : 8

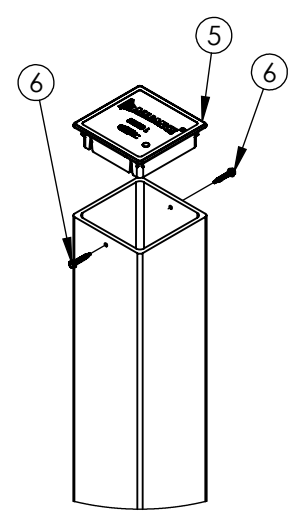
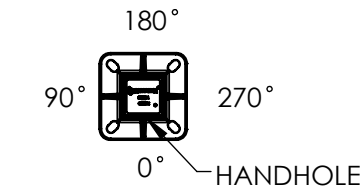

DETAIL C
TOP CAP ASSEMBLY
SCALE 1 : 8

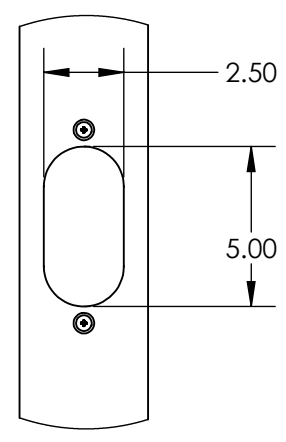

DETAIL A
HANDHOLE CUTOUT
COVER REMOVED FOR CLARITY

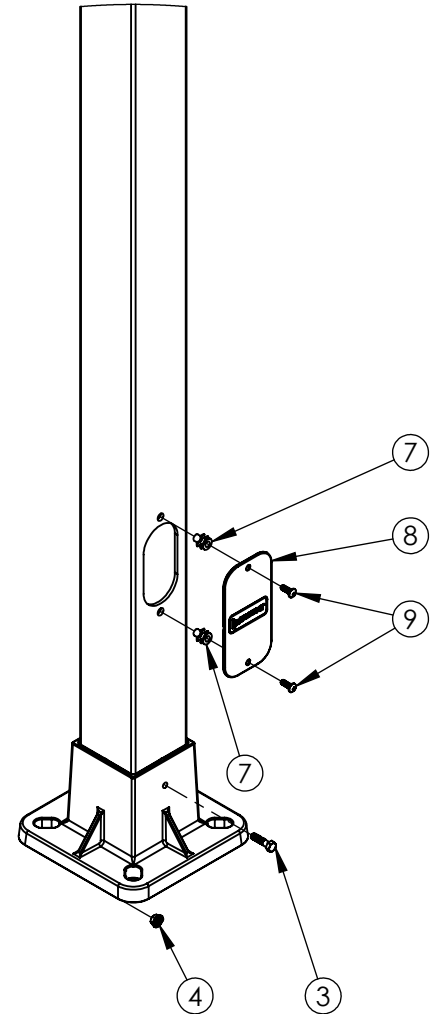

DETAIL D
BASE AND COVER
ASSEMBLY

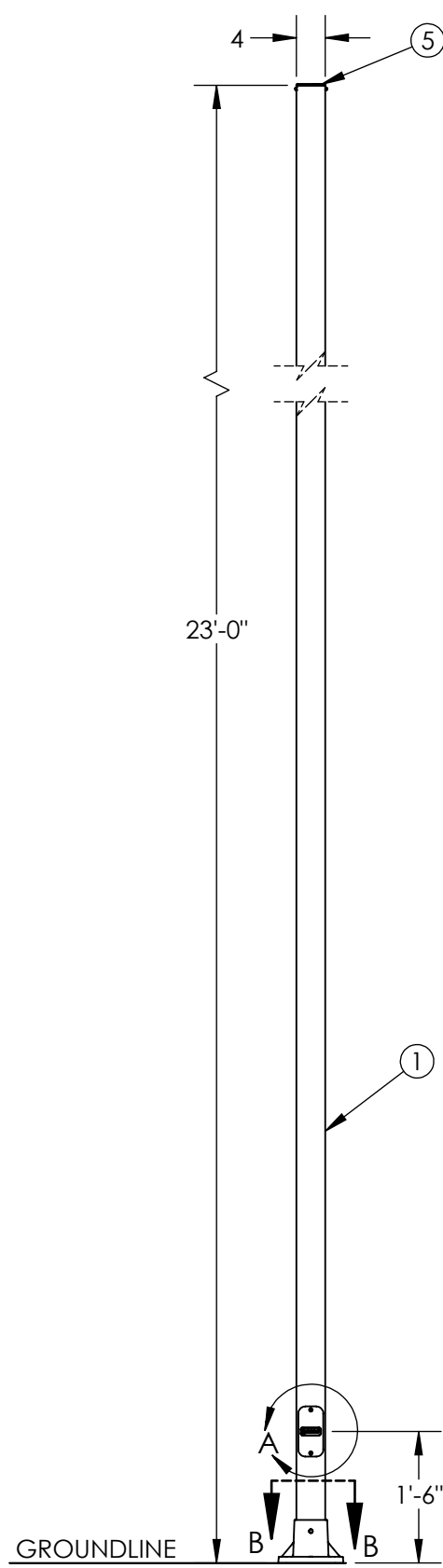

BUILD	STANDARD
FINISH	SMOOTH

MAXIMUM EPA PER WINDZONE										
MPH	90	100	110	120	130	140	150	160	170	180
EPA	4.1	2.1	0.6	-	-	-	-	-	-	-

A4SS23F00S1 ↓ GXHH

G = GRAY
A = BLACK
F = BRONZE
W = WHITE
N = GREEN

- NOTES:**
1. ANCHOR BASE CLASS 1 POLE PER ASTM 4923. POLE TOP DEFLECTION SHALL NOT EXCEED 15% OF THE ABOVE GROUND HEIGHT AT MAXIMUM WIND LOADING AND MAXIMUM FIXTURE WEIGHT.
 2. DESIGN CRITERIA PER AASHTO LTS-6-2013 WITH A MINIMUM SAFETY FACTOR OF 1.5 PER ANSI C136.20-2012.
 3. WIND SPEEDS DEFINED AS 3 SECOND GUST PER ASCE 7-16 WITH VELOCITY CONVERSIONS PER 2018 IBC 1609.3.1.

---UNLESS OTHERWISE SPECIFIED---
 DIMENSION UNITS ARE IN FEET AND INCHES
 DIMENSIONS SHOWN ARE NOMINAL

STATE:	RELEASED	2023-07-11
DRAWN:	CJM	2023-06-22
CHECKED:	DMF	2023-07-11
APPROVED:	AJH	2023-07-11
REPLACES:		



PROPRIETARY AND CONFIDENTIAL
 THE INFORMATION CONTAINED IN THIS DRAWING IS THE SOLE PROPERTY OF GEOTEK. ANY REPRODUCTION IN PART OR AS A WHOLE WITHOUT THE WRITTEN PERMISSION OF GEOTEK IS PROHIBITED.

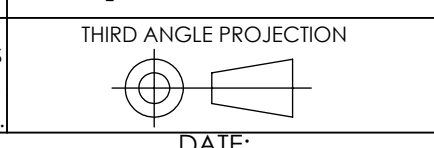

DESCRIPTION:
**POLE SYSTEM, ANCHOR BASE
 STANDARD DUTY, 23 FT**

1421 SECOND AVE NW
 STEWARTVILLE, MN 55976
 (800) 533-1680
 www.geotek.com

CUSTOMER SIGNATURE:

DATE:

SIZE: DWG. NO.
B A4SS23F00S1XGXHH

POLE COLOR: REV:
 SHEET 1 OF 1

SCALE: 1:10

SHEET 1 OF 1