

4

3

2

1

ITEM NO.	DESCRIPTION	QTY.
1	BEAM, PULTRUDED STOCK	1
2	ANCHOR BASE, 4" SQUARE	1
3	HEX BOLT	1
4	FLANGE NUT, SERRATED	1
5	TOP CAP	1
6	HEX SCREW, SELF-TAPPING	2
7	RIVET NUT, 1/4-20	2
8	HANDHOLE COVER	1
9	PHILLIPS SCREW, 1/4"-20x3/4"	2

REVISIONS				
REV.	DESCRIPTION	DATE	INITIALS	ECO
0.1	UPDATE NOTES	7/11/2023	AJH	6243

FEATURE ORIENTATIONS				
	0°	90°	180°	270°
HAND HOLE	X			

**NOTE:** ALL HOLES DRILLED ONLY THROUGH THE FACES SPECIFIED BY 'X'

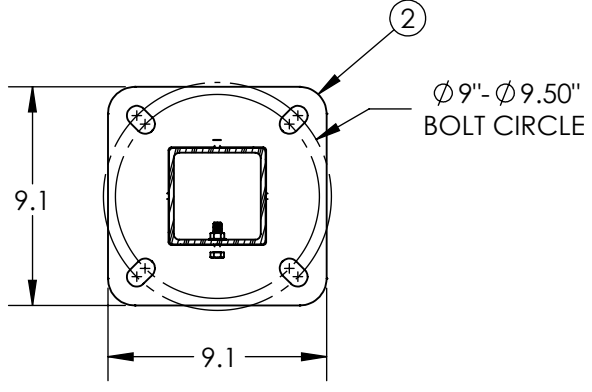

SECTION B-B  
SCALE 1 : 8

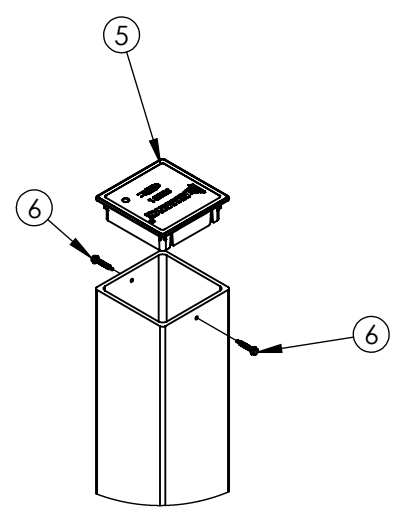
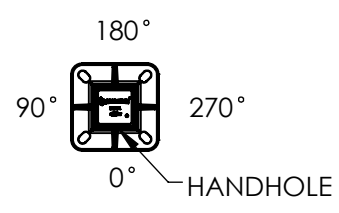

DETAIL C  
TOP CAP ASSEMBLY

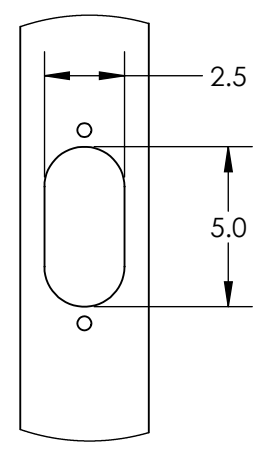

DETAIL A  
HANDHOLE CUTOUT  
COVER REMOVED FOR CLARITY  
SCALE 1 : 6

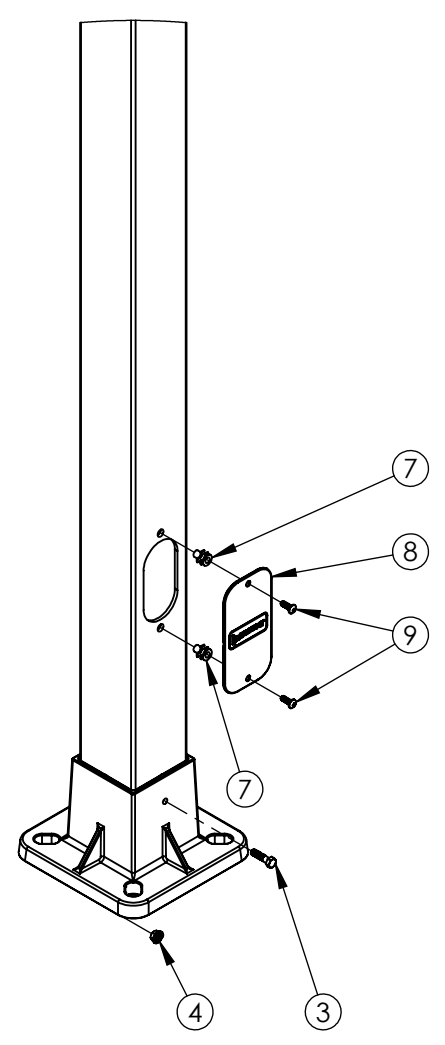

DETAIL D  
BASE AND COVER  
ASSEMBLY

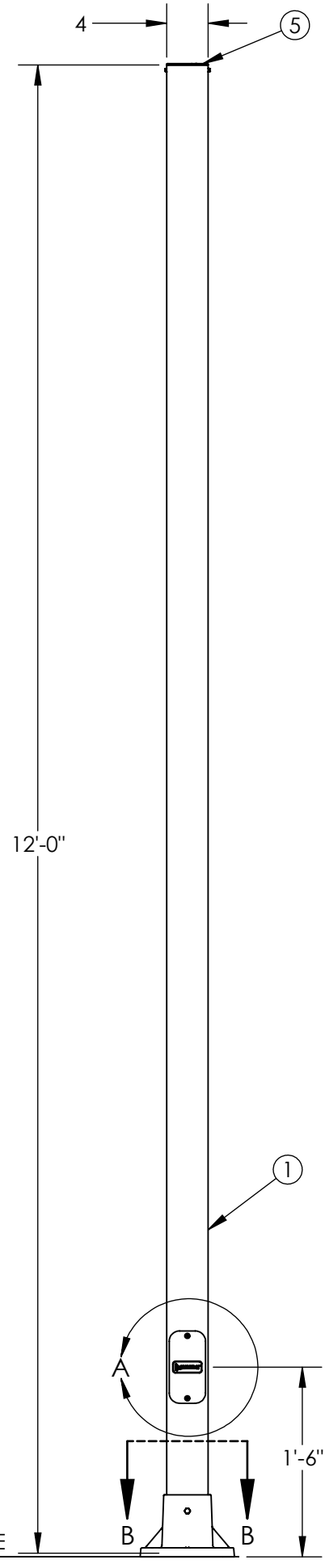

<b>BUILD</b>	STANDARD
<b>FINISH</b>	SMOOTH

MAXIMUM EPA PER WINDZONE										
MPH	90	100	110	120	130	140	150	160	170	180
EPA	17.7	13.7	10.8	8.5	6.9	6.5	5.2	4.2	3.3	2.6

A4SS12F00S1 ↓ GXHH

- G = GRAY**
- A = BLACK**
- F = BRONZE**
- W = WHITE**
- N = GREEN**

- NOTES:**
1. ANCHOR BASE CLASS 1 POLE PER ASTM 4923. POLE TOP DEFLECTION SHALL NOT EXCEED 15% OF THE ABOVE GROUND HEIGHT AT MAXIMUM WIND LOADING AND MAXIMUM FIXTURE WEIGHT.
  2. DESIGN CRITERIA PER AASHTO LTS-6-2013 WITH A MINIMUM SAFETY FACTOR OF 1.5 PER ANSI C136.20-2012.
  3. WIND SPEEDS DEFINED AS 3 SECOND GUST PER ASCE 7-16 WITH VELOCITY CONVERSIONS PER 2018 IBC 1609.3.1.

---UNLESS OTHERWISE SPECIFIED---  
DIMENSION UNITS ARE IN FEET AND INCHES  
DIMENSIONS SHOWN ARE NOMINAL

STATE:	RELEASED	2023-07-11
DRAWN:	AJH	2023-06-14
CHECKED:	DMF	2023-07-11
APPROVED:	AJH	2023-07-11
REPLACES:		



**PROPRIETARY AND CONFIDENTIAL**  
THE INFORMATION CONTAINED IN THIS DRAWING IS THE SOLE PROPERTY OF GEOTEK. ANY REPRODUCTION IN PART OR AS A WHOLE WITHOUT THE WRITTEN PERMISSION OF GEOTEK IS PROHIBITED.

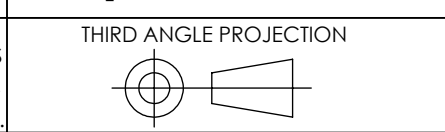

DESCRIPTION:  
**POLE ASSEMBLY, ANCHOR BASE  
STANDARD DUTY, 12FT**

1421 SECOND AVE NW  
STEWARTVILLE, MN 55976  
(800) 533-1680  
www.geotek.com

CUSTOMER SIGNATURE: \_\_\_\_\_ DATE: \_\_\_\_\_

SIZE: DWG. NO.  
**B A4SS12F00S1XGXHH**

POLE COLOR: \_\_\_\_\_ REV: 0.1