

4

3

2

1

ITEM NO.	DESCRIPTION	QTY.
1	BEAM, PULTRUDED STOCK	1
2	HANDHOLE COVER	1
3	RIVET NUT, 1/4-20	2
4	PHILLIPS SCREW, 1/4"-20x3/4"	2
5	TOP CAP, T5	1
6	HEX SCREW, #8-18 x 1 in	2

REVISIONS				
REV.	DESCRIPTION	DATE	INITIALS	ECO

FEATURE ORIENTATIONS				
	0°	90°	180°	270°
HAND HOLE	X			
CABLE ENTRY	X			

**NOTE:** ALL HOLES DRILLED ONLY THROUGH THE FACES SPECIFIED BY 'X'

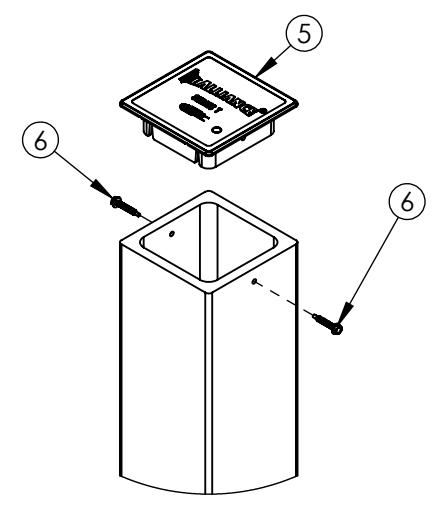
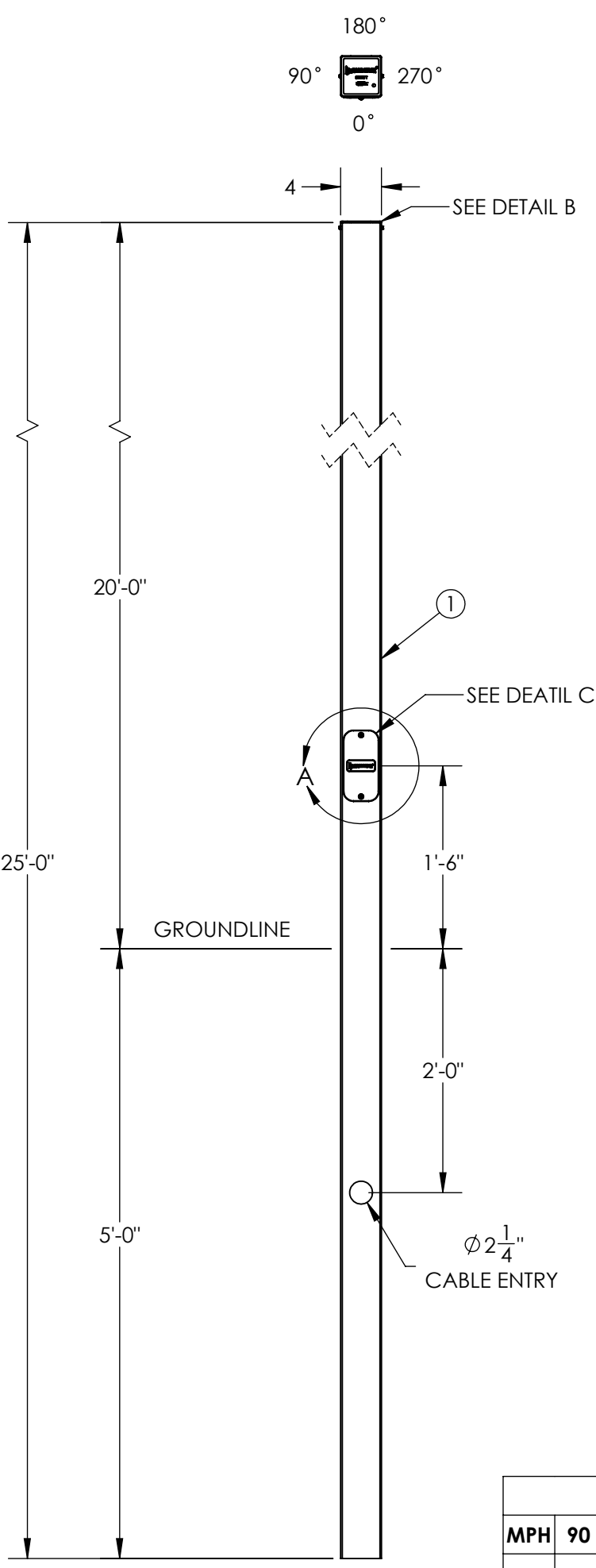

DETAIL B  
TOP CAP ASSEMBLY  
SCALE 1 : 6

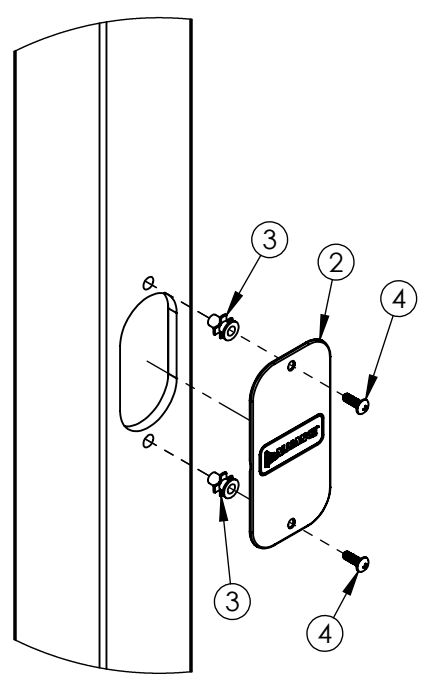

DETAIL C  
COVER ASSEMBLY

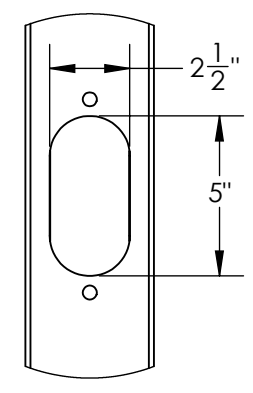

DETAIL A  
HANDHOLE CUTOUT  
COVER REMOVED FOR CLARITY  
SCALE 1 : 6

<b>BUILD</b>	HEAVY
<b>FINISH</b>	SMOOTH

MAXIMUM EPA PER WINDZONE										
MPH	90	100	110	120	130	140	150	160	170	180
EPA	29.7	23.0	18.0	14.2	11.5	10.9	8.7	7.0	5.5	4.3

- NOTES:
1. DIRECT BURIAL CLASS 1 POLE PER ASTM 4923. POLE TOP DEFLECTION SHALL NOT EXCEED 15% OF THE ABOVE GROUND HEIGHT AT MAXIMUM WIND LOADING AND MAXIMUM FIXTURE WEIGHT.
  2. DESIGN CRITERIA PER AASHTO LTS-6-2013 WITH A MINIMUM SAFETY FACTOR OF 1.5 PER ANSI C136.20-2012.
  3. WIND SPEEDS DEFINED AS 3 SECOND GUST PER ASCE 7-16 WITH VELOCITY CONVERSIONS PER 2018 IBC 1609.3.1.
  4. EMBEDMENT BASED ON MINIMUM DEPTH RECOMMENDED BY ANSI C136.20-2012 SECTION 5.3 AND ASSUMING CLASS 1 SOIL OR BETTER WHEN LOADED AT MAXIMUM EPA.

D5SH25F00S1 ↓ GXHH

- G = GRAY**
- A = BLACK**
- F = BRONZE**
- W = WHITE**
- N = GREEN**

---UNLESS OTHERWISE SPECIFIED---  
DIMENSION UNITS ARE IN FEET AND INCHES  
DIMENSIONS SHOWN ARE NOMINAL

STATE:	RELEASED	2024-04-16
DRAWN:	ARK	2024-04-15
CHECKED:	NDH	2024-04-15
APPROVED:	ARK	2024-04-16
REPLACES:	-	



**PROPRIETARY AND CONFIDENTIAL**  
THE INFORMATION CONTAINED IN THIS DRAWING IS THE SOLE PROPERTY OF GEOTEK. ANY REPRODUCTION IN PART OR AS A WHOLE WITHOUT THE WRITTEN PERMISSION OF GEOTEK IS PROHIBITED.

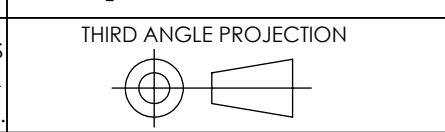

DESCRIPTION:  
**POLE ASSEMBLY, DIRECT BURIAL HEAVY DUTY, 25FT**

1421 SECOND AVE NW  
STEWARTVILLE, MN 55976  
(800) 533-1680  
www.geotek.com

CUSTOMER SIGNATURE: \_\_\_\_\_ DATE: \_\_\_\_\_

**-REFERENCES-**  
alliancecompositesinc.com/warranty  
geotek.com/termsandconditions

SIZE: DWG. NO.  
**B D5SH25F00S1XGXHH**

POLE COLOR: REV:  
0.0