

| ITEM NO. | DESCRIPTION                  | QTY. |
|----------|------------------------------|------|
| 1        | BEAM, PULTRUDED STOCK        | 1    |
| 2        | HANDHOLE COVER               | 1    |
| 3        | RIVET NUT, 1/4-20            | 2    |
| 4        | PHILLIPS SCREW, 1/4"-20x3/4" | 2    |
| 5        | TOP CAP, T5                  | 1    |
| 6        | HEX SCREW, #8-18 x 1 in      | 2    |

| REVISIONS |             |      |          |     |
|-----------|-------------|------|----------|-----|
| REV.      | DESCRIPTION | DATE | INITIALS | ECO |
|           |             |      |          |     |

| FEATURE ORIENTATIONS |    |     |      |      |
|----------------------|----|-----|------|------|
|                      | 0° | 90° | 180° | 270° |
| HAND HOLE            | X  |     |      |      |
| CABLE ENTRY          | X  |     |      |      |

**NOTE:** ALL HOLES DRILLED ONLY THROUGH THE FACES SPECIFIED BY 'X'

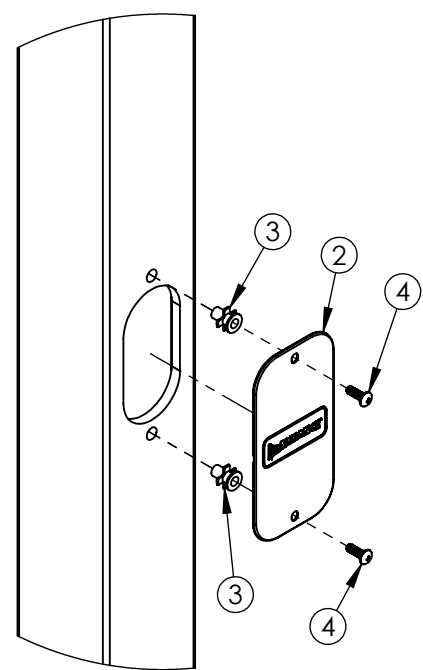
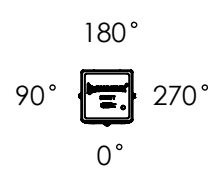

DETAIL C  
COVER ASSEMBLY

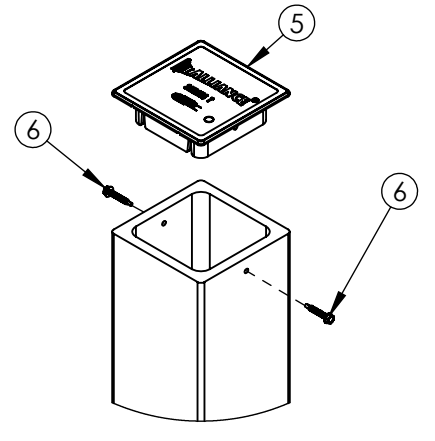
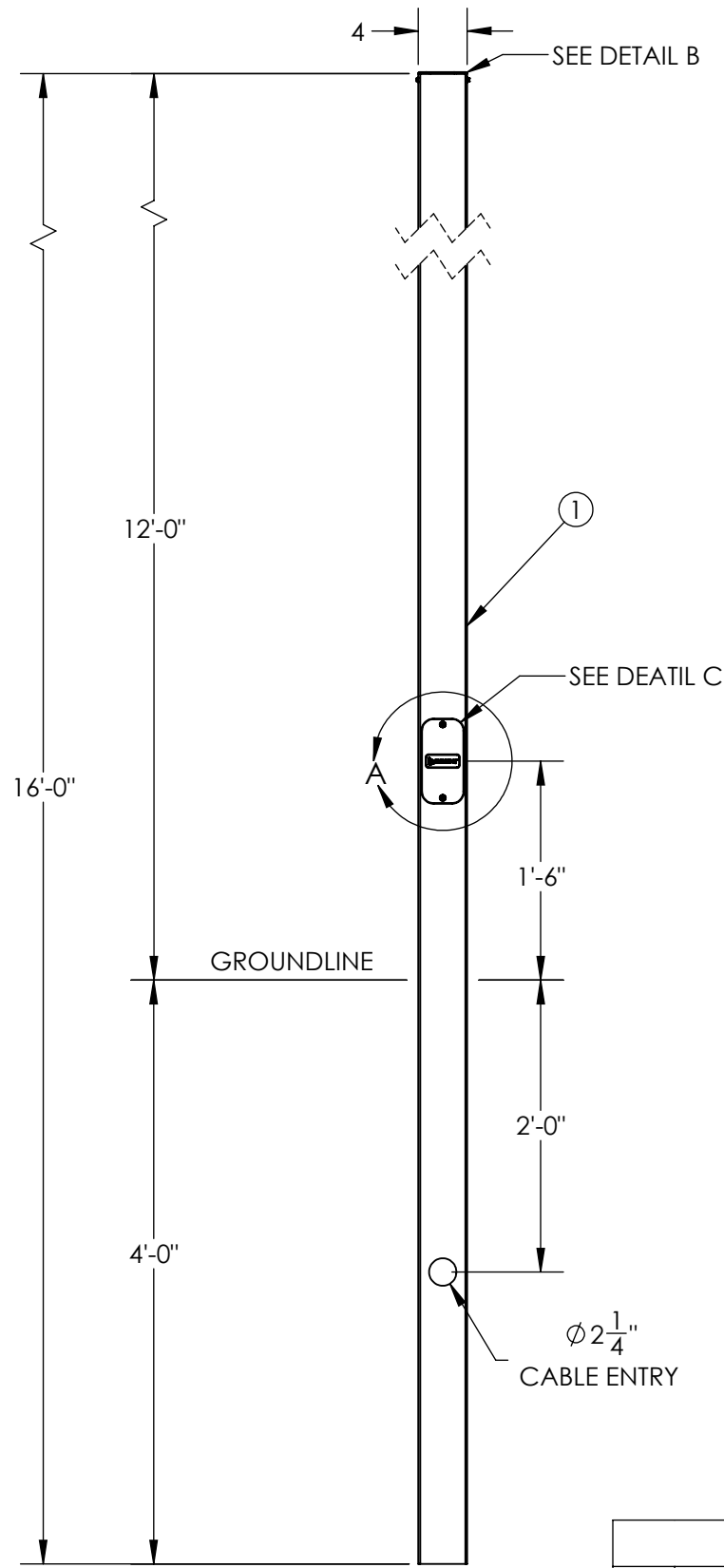

DETAIL B  
TOP CAP ASSEMBLY  
SCALE 1 : 6

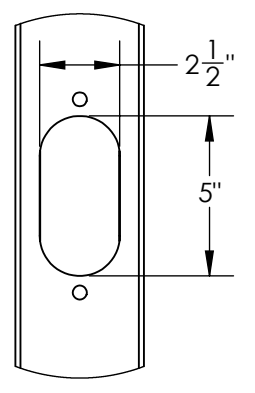

DETAIL A  
HANDHOLE CUTOUT  
COVER REMOVED FOR CLARITY  
SCALE 1 : 6

|               |        |
|---------------|--------|
| <b>BUILD</b>  | HEAVY  |
| <b>FINISH</b> | SMOOTH |

| MAXIMUM EPA PER WINDZONE |      |      |      |      |      |      |      |      |     |      |
|--------------------------|------|------|------|------|------|------|------|------|-----|------|
| MPH                      | 90   | 100  | 110  | 120  | 130  | 140  | 150  | 160  | 170 | 180  |
| EPA                      | 60.8 | 48.6 | 39.6 | 32.7 | 27.8 | 26.6 | 22.8 | 19.6 | 17  | 14.8 |

- NOTES:
- DIRECT BURIAL CLASS 1 POLE PER ASTM 4923. POLE TOP DEFLECTION SHALL NOT EXCEED 15% OF THE ABOVE GROUND HEIGHT AT MAXIMUM WIND LOADING AND MAXIMUM FIXTURE WEIGHT.
  - DESIGN CRITERIA PER AASHTO LTS-6-2013 WITH A MINIMUM SAFETY FACTOR OF 1.5 PER ANSI C136.20-2012.
  - WIND SPEEDS DEFINED AS 3 SECOND GUST PER ASCE 7-16 WITH VELOCITY CONVERSIONS PER 2018 IBC 1609.3.1.
  - EMBEDMENT BASED ON MINIMUM DEPTH RECOMMENDED BY ANSIC136.20-2012 SECTION 5.3. EMBEDMENT SHOWN MAY REQUIRE BACKFILL BETTER THAN CLASS 1 SOIL IF LOADED TO MAXIMUM EPA'S. CONTACT ALLIANCE ENGINEERING FOR DEATILS.

D4SH16F00S1 ↓ GXHH

**G = GRAY**  
**A = BLACK**  
**F = BRONZE**  
**W = WHITE**  
**N = GREEN**

---UNLESS OTHERWISE SPECIFIED---  
 DIMENSION UNITS ARE IN FEET AND INCHES  
 DIMENSIONS SHOWN ARE NOMINAL



**PROPRIETARY AND CONFIDENTIAL**  
 THE INFORMATION CONTAINED IN THIS DRAWING IS THE SOLE PROPERTY OF GEOTEK. ANY REPRODUCTION IN PART OR AS A WHOLE WITHOUT THE WRITTEN PERMISSION OF GEOTEK IS PROHIBITED.

CUSTOMER SIGNATURE: \_\_\_\_\_ DATE: \_\_\_\_\_

STATE: RELEASED 2024-04-16  
 DRAWN: ARK 2024-04-12  
 CHECKED: NDH 2024-04-15  
 APPROVED: ARK 2024-04-16  
 REPLACES: -

THIRD ANGLE PROJECTION

**-REFERENCES-**  
 alliancecompositesinc.com/warranty  
 geotek.com/termsandconditions

DESCRIPTION:  
**POLE ASSEMBLY, DIRECT BURIAL HEAVY DUTY, 16FT**

1421 SECOND AVE NW  
 STEWARTVILLE, MN 55976  
 (800) 533-1680  
 www.geotek.com

SIZE: DWG. NO. **B D4SH16F00S1XGXHH** POLE COLOR: REV: 0.0

SCALE: 1:18 SHEET 1 OF 1