

4

3

2

1

ITEM NO.	DESCRIPTION	QTY.
1	BEAM, PULTRUDED STOCK	1
2	ANCHOR BASE, 4" SQUARE	1
3	HEX BOLT	1
4	FLANGE NUT, SERRATED	1
5	TOP CAP, T5	1
6	HEX SCREW, #8-18 x 1 in	2
7	RIVET NUT, 1/4-20	2
8	HANDHOLE COVER	1
9	PHILLIPS SCREW, 1/4"-20x3/4"	2

REVISIONS				
REV.	DESCRIPTION	DATE	INITIALS	ECO

FEATURE ORIENTATIONS				
	0°	90°	180°	270°
HAND HOLE	X			

NOTE: ALL HOLES DRILLED ONLY THROUGH THE FACES SPECIFIED BY 'X'

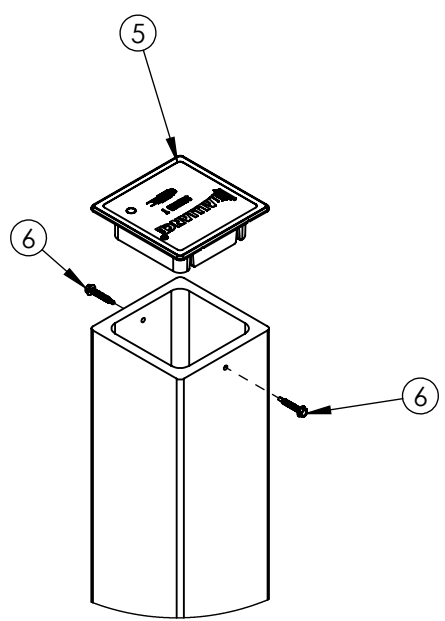
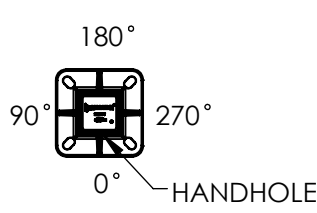

DETAIL C
TOP CAP ASSEMBLY
SCALE 1 : 6

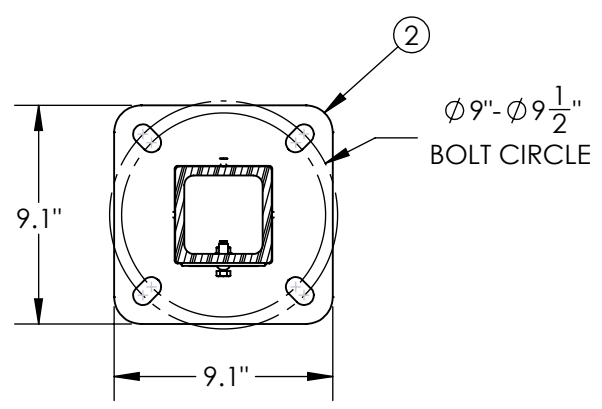

SECTION B-B
SCALE 1 : 8

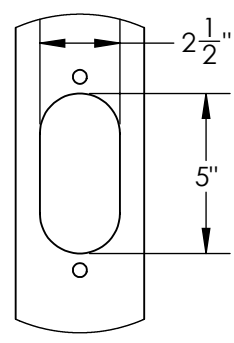
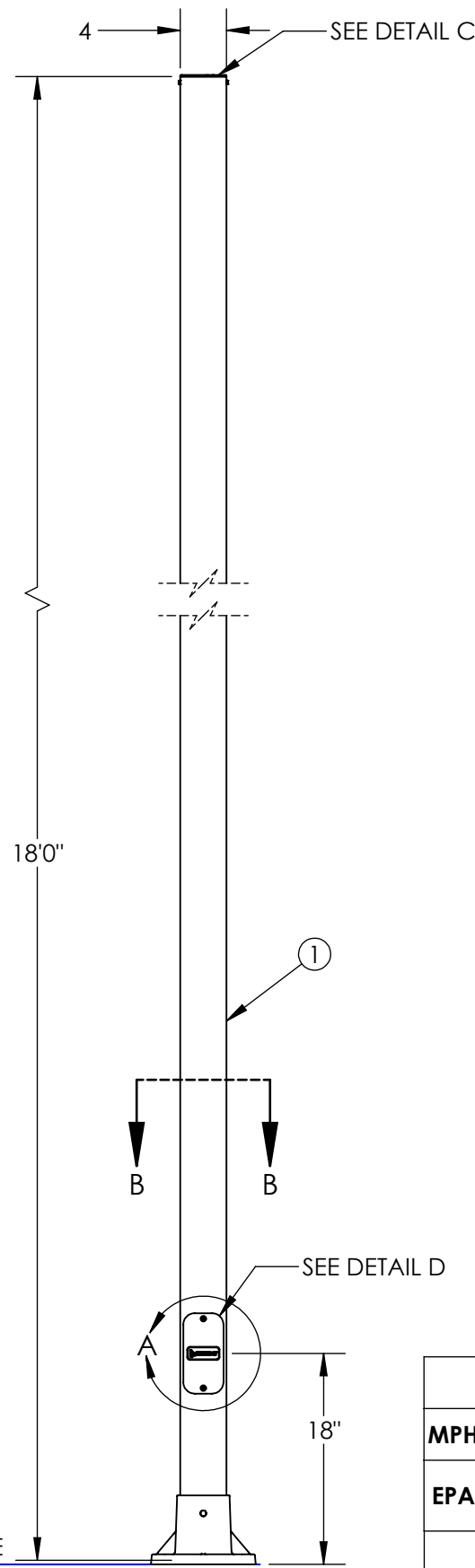

DETAIL A
HANDHOLE CUTOUT
COVER REMOVED FOR CLARITY
SCALE 1 : 6

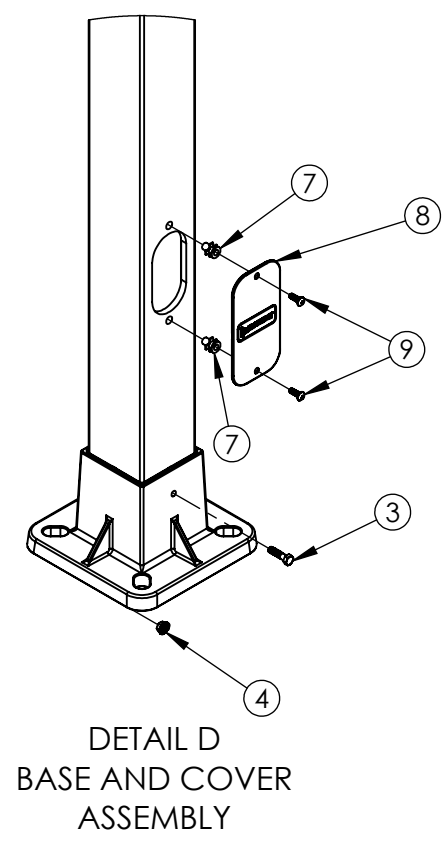

DETAIL D
BASE AND COVER
ASSEMBLY

BUILD	HEAVY
FINISH	SMOOTH

MAXIMUM EPA PER WINDZONE										
MPH	90	100	110	120	130	140	150	160	170	180
EPA	20.9	16	12.3	9.5	7.6	7.1	5.5	4.2	3.1	2.3

A4SH18F00S1 ↓ GXHH

- G = GRAY**
- A = BLACK**
- F = BRONZE**
- W = WHITE**
- N = GREEN**

- NOTES:**
- ANCHOR BASE CLASS 1 POLE PER ASTM 4923. POLE TOP DEFLECTION SHALL NOT EXCEED 15% OF THE ABOVE GROUND HEIGHT AT MAXIMUM WIND LOADING AND MAXIMUM FIXTURE WEIGHT.
 - DESIGN CRITERIA PER AASHTO LTS-6-2013 WITH A MINIMUM SAFETY FACTOR OF 1.5 PER ANSI C136.20-2012.
 - WIND SPEEDS DEFINED AS 3 SECOND GUST PER ASCE 7-16 WITH VELOCITY CONVERSIONS PER 2018 IBC 1609.3.1.

---UNLESS OTHERWISE SPECIFIED--- DIMENSION UNITS ARE IN FEET AND INCHES DIMENSIONS SHOWN ARE NOMINAL	STATE:	RELEASED	2024-04-15
	DRAWN:	ARK	2024-04-11
	CHECKED:	AKS	2024-04-15
	APPROVED:	ARK	2024-04-15
	REPLACES:		



PROPRIETARY AND CONFIDENTIAL
THE INFORMATION CONTAINED IN THIS DRAWING IS THE SOLE PROPERTY OF GEOTEK. ANY REPRODUCTION IN PART OR AS A WHOLE WITHOUT THE WRITTEN PERMISSION OF GEOTEK IS PROHIBITED.

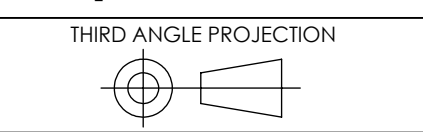

DESCRIPTION:
**POLE ASSEMBLY, ANCHOR BASE
HEAVY DUTY, 18FT**

1421 SECOND AVE NW
STEWARTVILLE, MN 55976
(800) 533-1680
www.geotek.com

CUSTOMER SIGNATURE: _____ DATE: _____

-REFERENCES-
alliancecompositesinc.com/warranty
geotek.com/termsandconditions

SIZE: DWG. NO.
B A4SH18F00S1XGXHH

POLE COLOR: REV:
0.0

SCALE: 1:10

SHEET 1 OF 1